

1 TERCEL ELECTRICAL WIRING DIAGRAM –1993 Model(Location No. 1 to 17)

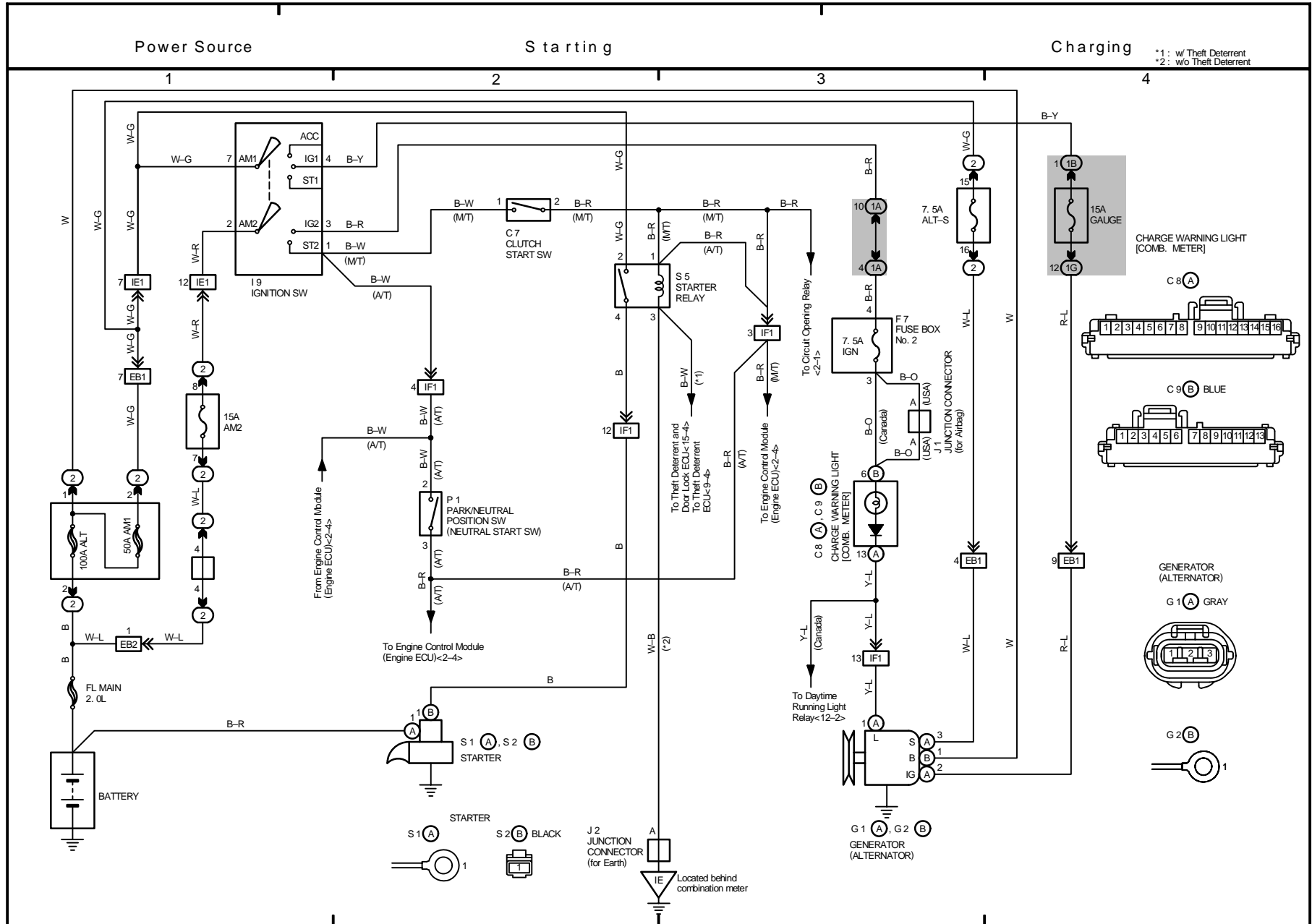

3 TERCEL

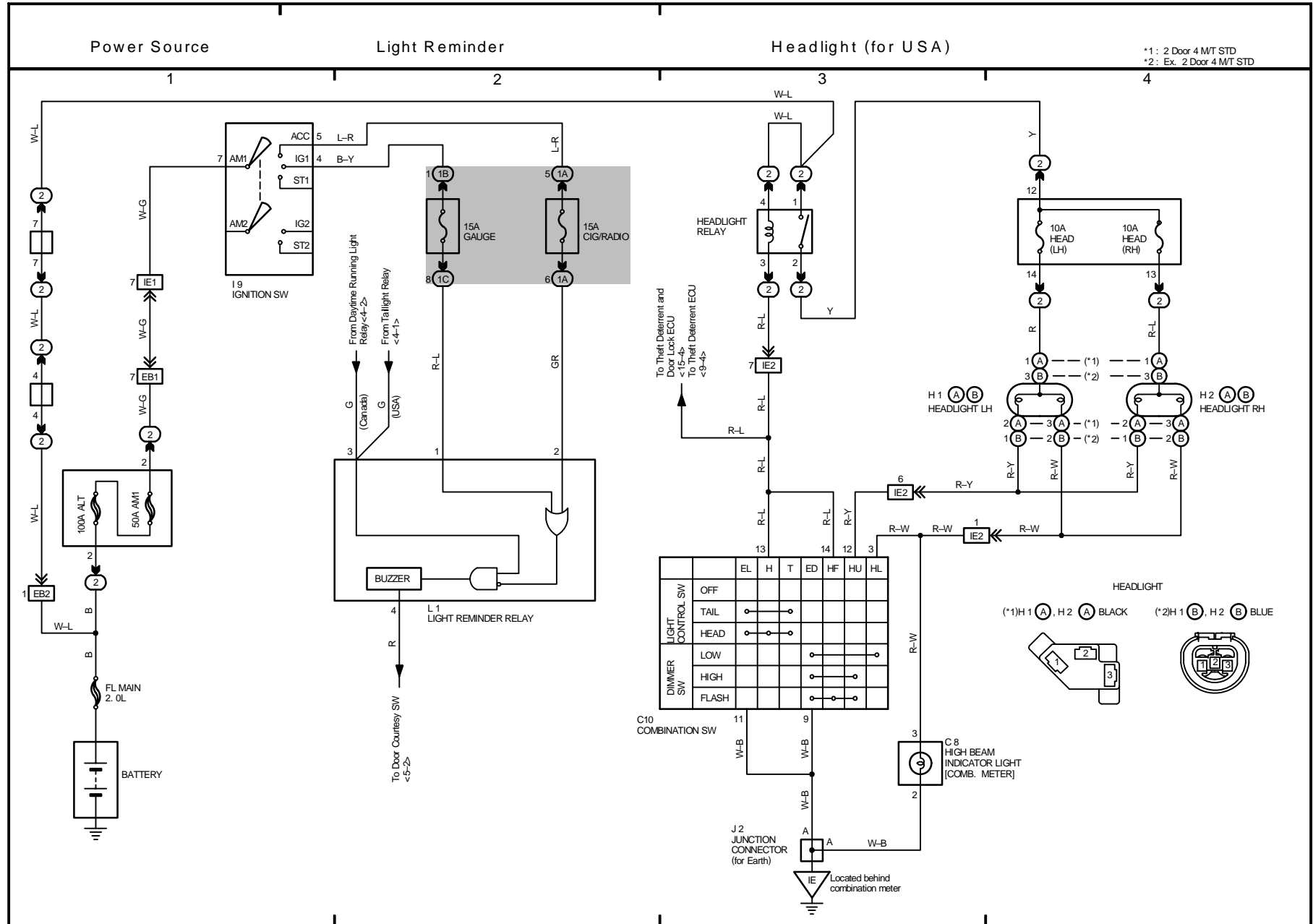

OVERALL ELECTRICAL WIRING DIAGRAM

4 TERCEL

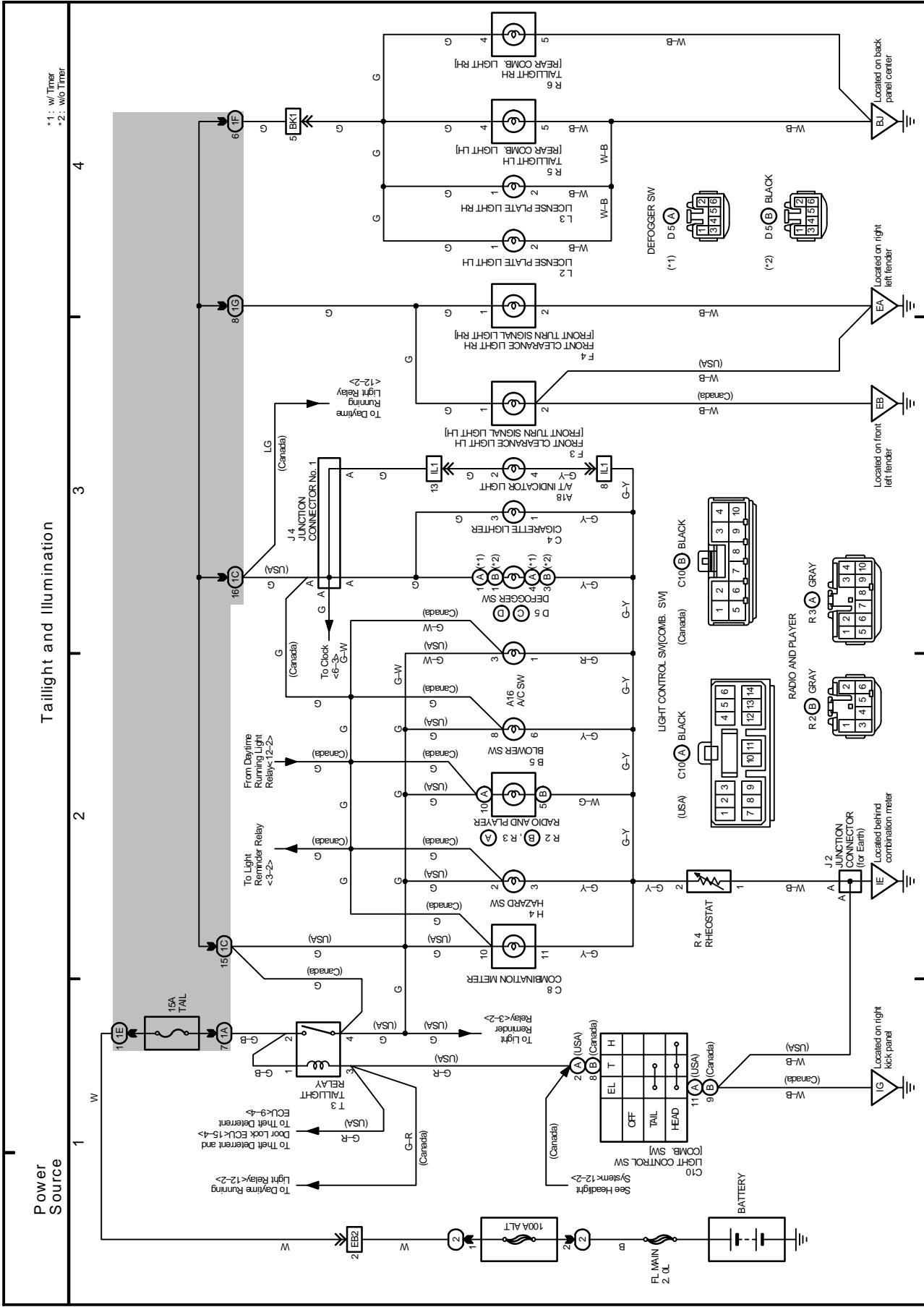

OVERALL ELECTRICAL WIRING DIAGRAM

8 TERCEL

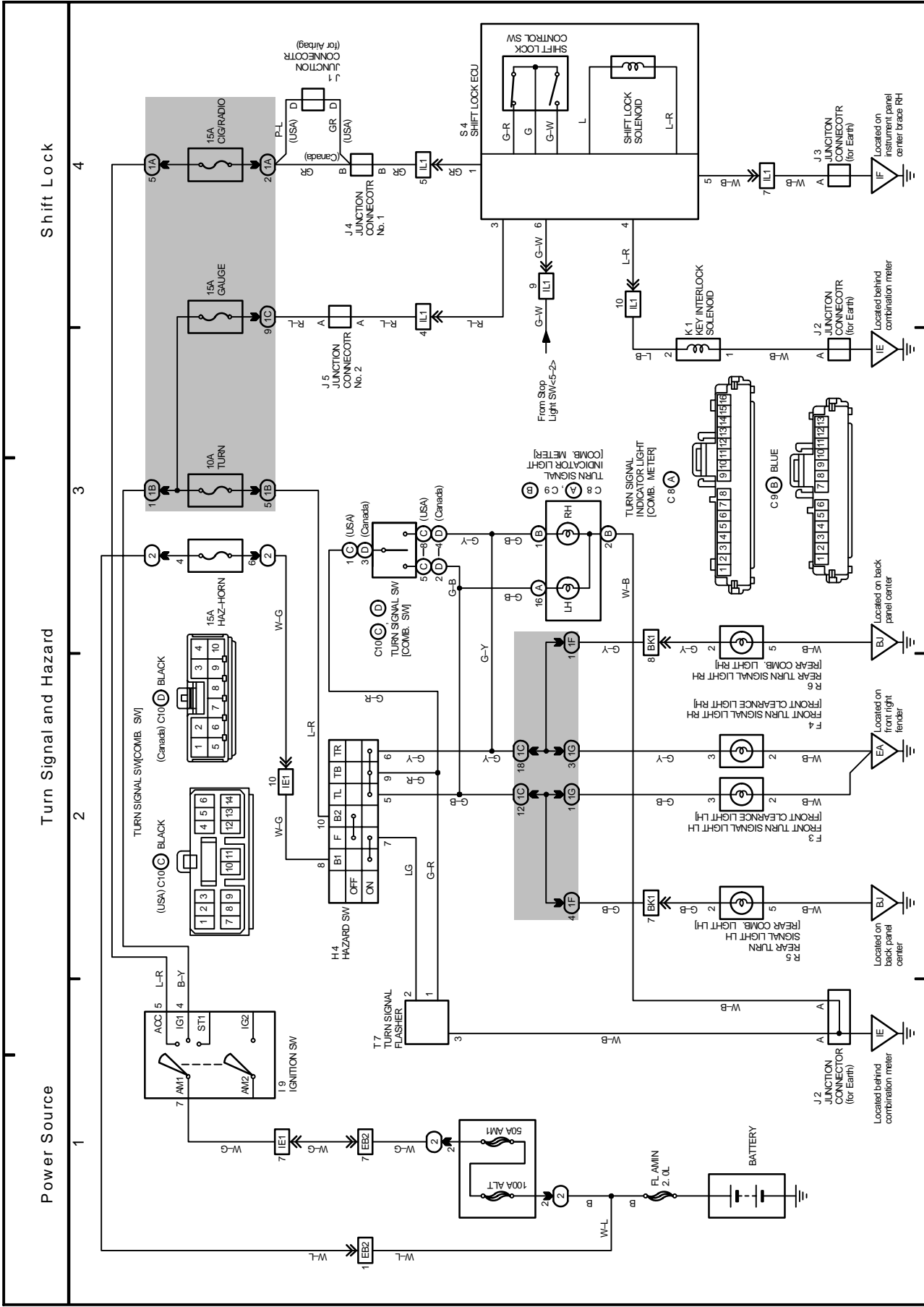

9 TERCEL

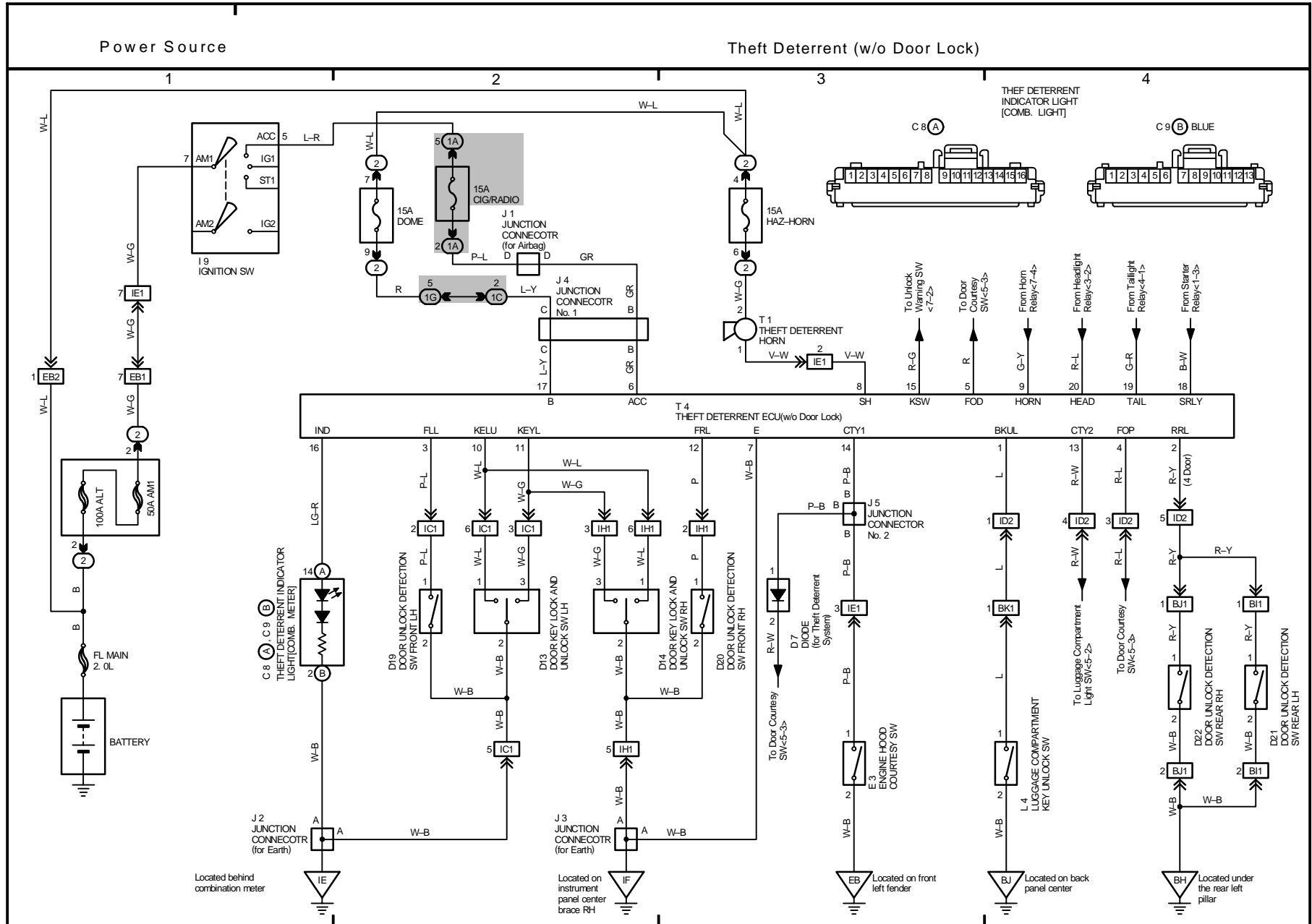

OVERALL ELECTRICAL WIRING DIAGRAM

Radiator Fan and Air Conditioning

*1: w/Power Steering

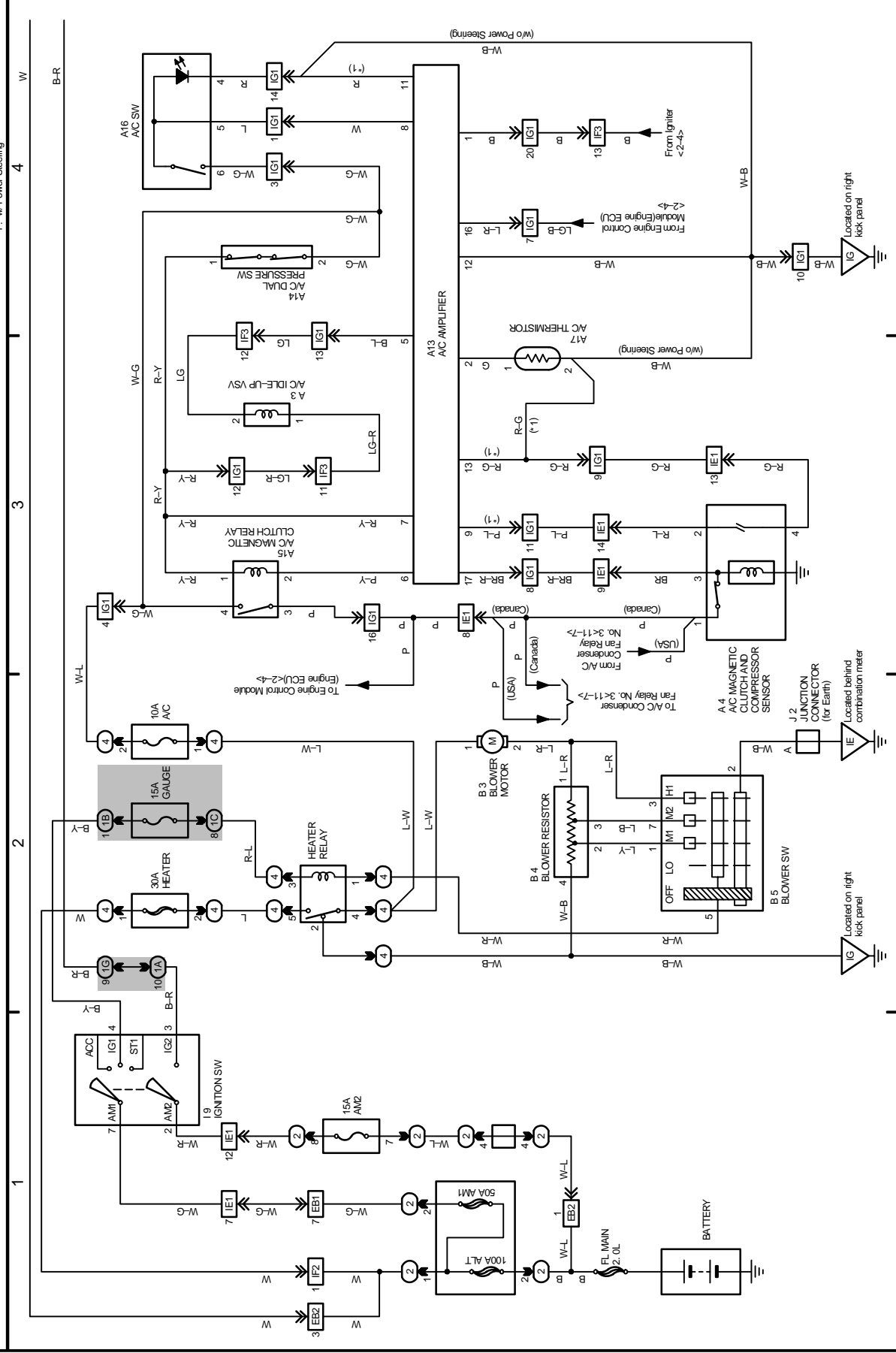

11 TERCEL (Cont'd)

Radiator Fan and Air Conditioning

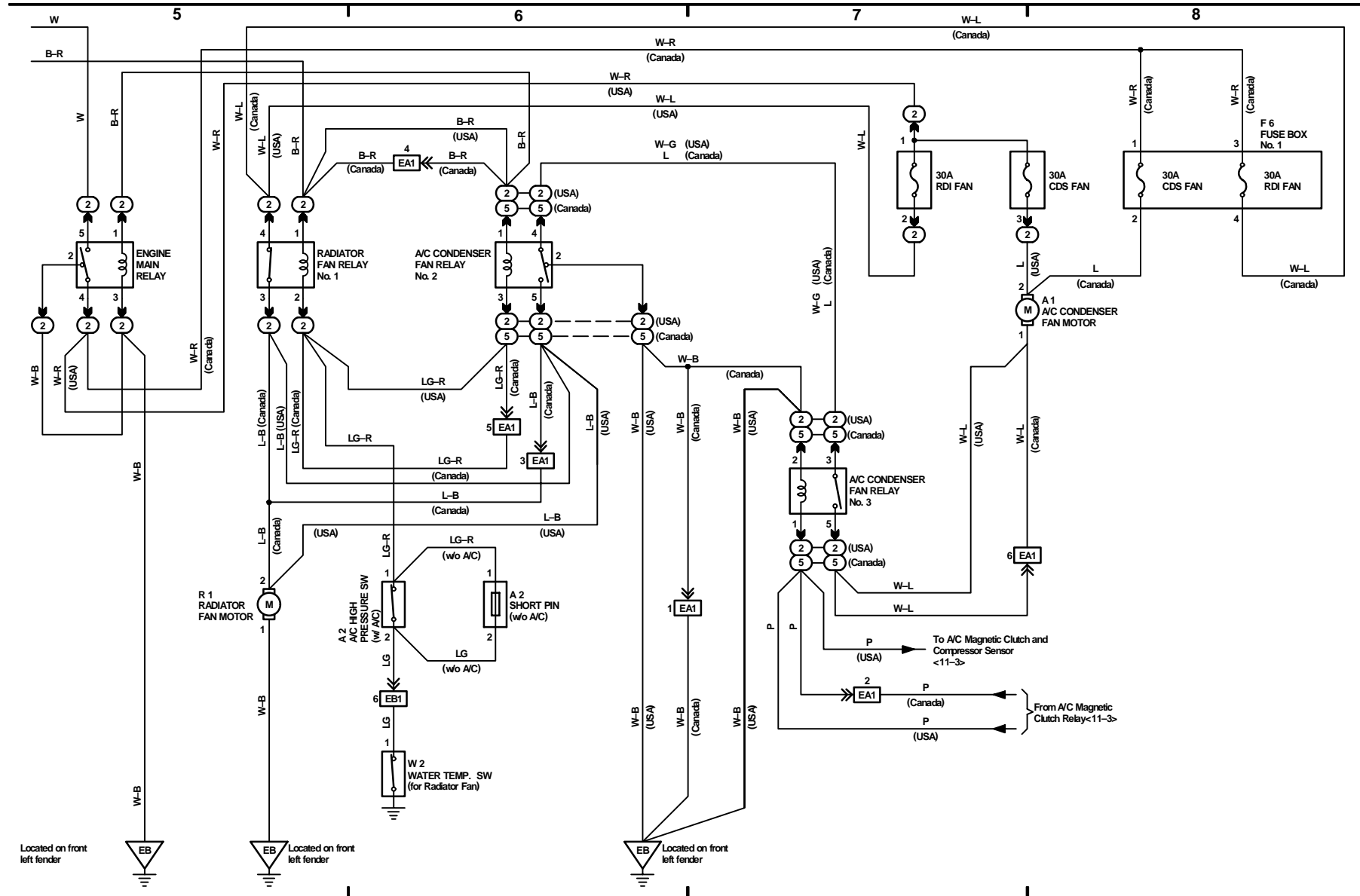

13 TERCEL

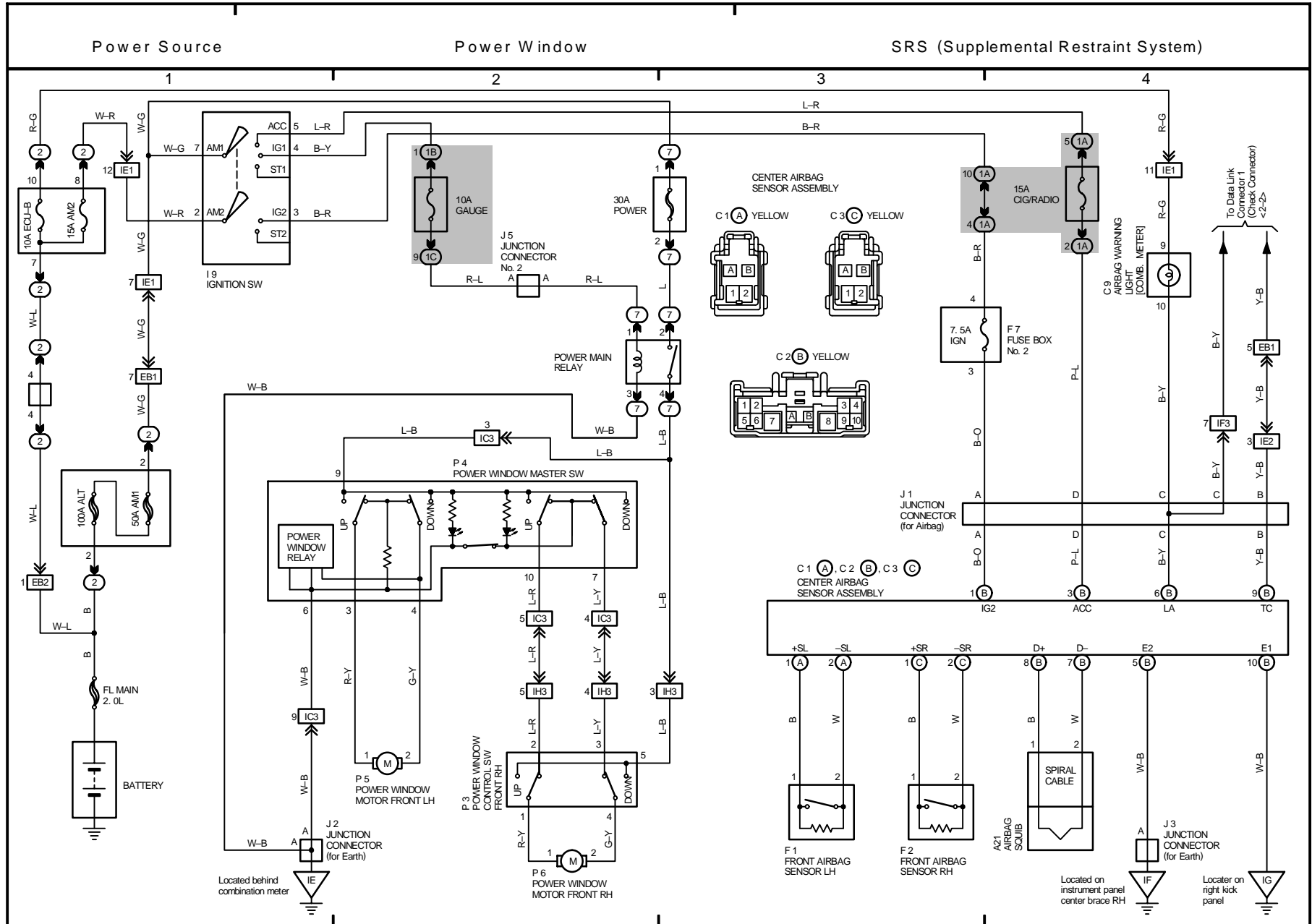

OVERALL ELECTRICAL WIRING DIAGRAM

14 TERCEL

ABS (Anti-Lock Brake System)

Power Source

